



DC36-12 (12V36Ah)

DC (Deep Cycle) series is specially designed for frequent deep cycle discharge. By using the specially designed active material and strong grids, the DC series battery offers reliable performance in high load situations and can deliver more than 300 cycles at 100% DOD. Suitable for mobility scooters, electric wheel chairs, golf buggies etc.



Specification

Cells Per Unit	6
Voltage Per Unit	12
Capacity	33Ah@10hr-rate to 1.80V per cell @25°C
Weight	Approx. 10.2 Kg(Tolerance±3%)
Max. Discharge Current	330 A (5 sec)
Internal Resistance	Approx. 9 mΩ
Operating Temperature Range	Discharge: -20°C~60°C Charge: 0°C~50°C Storage: -20°C~60°C
Normal Operating Temperature Range	25°C±5°C
Float charging Voltage	13.6 to 13.8 VDC/unit Average at 25°C
Recommended Maximum Charging Current Limit	9.9 A
Equalization and Cycle Service	14.6 to 14.8 VDC/unit Average at 25°C
Self Discharge	VMF Valve Regulated Lead Acid (VRLA) batteries can be stored for more than 6 months at 25°C. Self-discharge ratio less than 3% per month at 25°C. Please charge batteries before using.
Terminal	Terminal F7/F11
Constainer Material	A.B.S. UL94-HB, UL94-V0 Optional.



MH28539



G4M20206-0910-E-16



THE INTERNATIONAL CERTIFICATION NETWORK

CERTIFICATE

Postcode: 421001

is in conformity with

ISO 14001:2004 Standard



THE INTERNATIONAL CERTIFICATION NETWORK

CERTIFICATE

Postcode: 421001

is in conformity with

OHSAS 18001:1999 Standard

Dimensions

Unit: mm Dimension: 195(L)×130(W)×180(H)

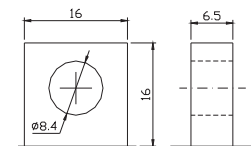
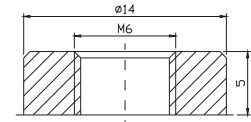
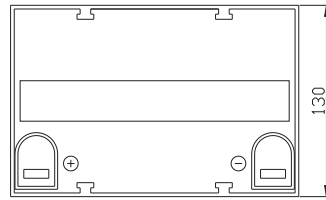
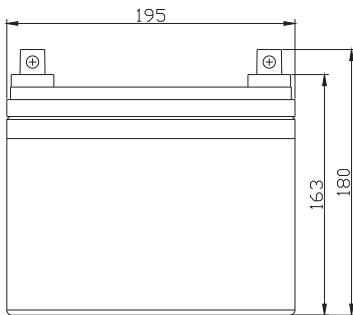

Constant Current Discharge Characteristics: A(25°C)

F.V/Time	5MIN	10MIN	15MIN	30MIN	1HR	2HR	3HR	4HR	5HR	8HR	10HR	20HR
9.60V	118.0	86.86	64.10	37.51	21.45	13.08	8.825	7.338	5.848	4.220	3.434	1.818
10.0V	114.6	82.65	62.78	36.87	21.02	12.99	8.758	7.304	5.811	4.185	3.400	1.784
10.2V	111.2	79.73	61.80	36.18	20.49	12.89	8.593	7.270	5.775	4.151	3.367	1.750
10.5V	99.83	73.57	58.84	35.91	20.06	12.79	8.392	7.202	5.702	4.117	3.333	1.716
10.8V	90.10	67.09	54.24	35.30	19.47	12.56	8.254	7.032	5.659	4.048	3.303	1.699
11.1V	76.94	59.96	48.65	33.05	18.78	12.00	8.111	6.692	5.517	3.877	3.264	1.630

Constant Power Discharge Characteristics: W(25°C)

F.V/Time	5MIN	10MIN	15MIN	30MIN	1HR	2HR	3HR	4HR	5HR	8HR	10HR	20HR
9.60V	1245	934.3	709.2	429.4	247.9	155.3	104.95	87.46	70.04	50.38	41.20	22.39
10.0V	1220	905.7	697.9	424.1	247.3	154.8	104.50	87.35	69.53	50.14	40.94	22.00
10.2V	1206	881.8	692.6	420.4	245.4	153.9	102.89	87.16	69.30	49.81	40.57	21.60
10.5V	1098.1	821.1	671.4	422.4	240.5	153.4	100.61	86.35	68.64	49.40	40.18	21.19
10.8V	1000.2	756.9	620.5	415.6	233.7	151.1	99.40	84.38	67.92	48.58	39.78	20.78
11.1V	878.5	690.9	569.6	391.4	225.5	144.6	97.70	80.31	66.32	46.52	39.27	20.18

All mentioned values are average values(Tolerance±2%).

Life characteristics of cyclic use

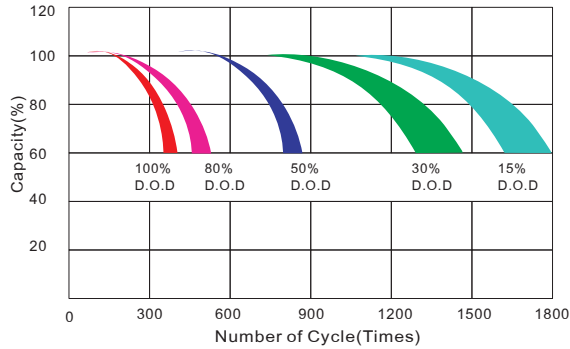

Storage characteristic

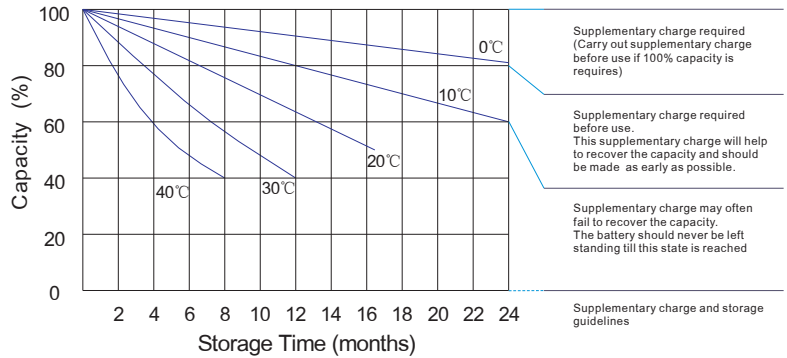

Charge characteristic Curve for standby use

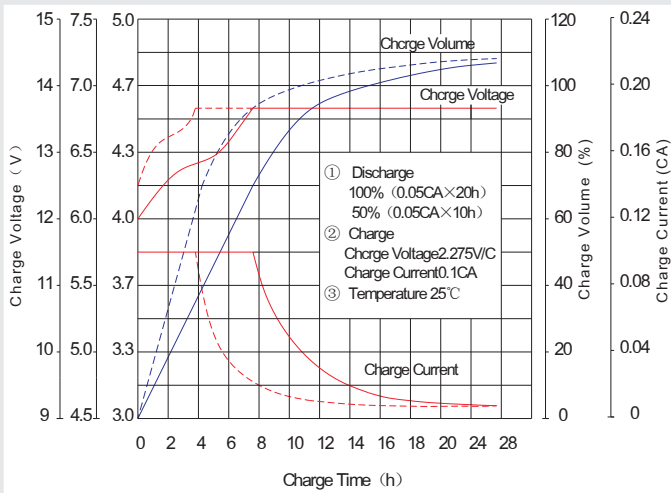

Discharge characteristic Curve

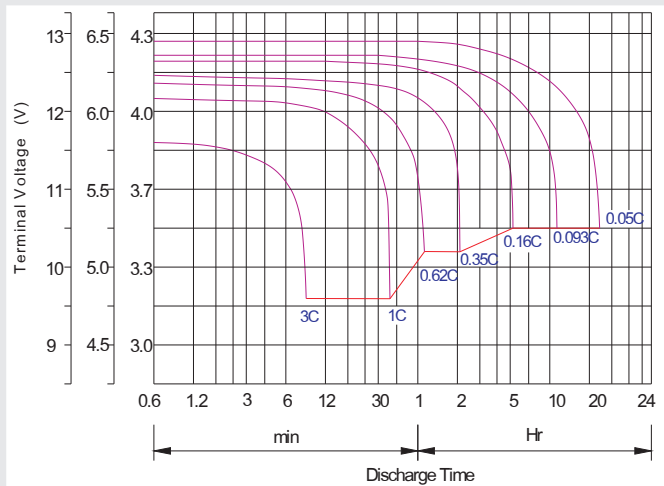

Capacity Factors With Different Temperature

Battery Type		-20°C	-10°C	0°C	5°C	10°C	20°C	25°C	30°C	40°C	45°C
GEL Battery	6V&12V	50%	70%	83%	85%	90%	98%	100%	102%	104%	105%
	2V	60%	75%	85%	88%	92%	99%	100%	103%	105%	106%
AGM Battery	6V&12V	46%	66%	76%	83%	90%	98%	100%	103%	107%	109%
	2V	55%	70%	80%	85%	92%	99%	100%	104%	108%	110%

Discharge Current VS. Discharge Voltage

Final Discharge Voltage V/cell	1.75V	1.70V	1.60V
Discharge Current (A)	(A) ≤ 0.2C	0.2C < (A) < 1.0C	(A) ≥ 1.0C

Maintenance & Cautions

Charge the batteries at least once every six months, if they are stored at 25°C.

Charging Method:

Constant Voltage	-0.2Cx2h+2.4-2.45V/cellx24h, Max. Current 0.3C
Constant Current	-0.2Cx2h+0.1Cx12h
Fast	-0.2Cx2h+0.3Cx4h

Cycle service

- ※ Avoid battery over discharge, especially battery series connection use.
- ※ Charged with recommend voltage, ensure battery can be full recharged.
- In general, recharge capacity should be 1.1-1.15 times discharge capacity.
- ※ Effect of temperature on cycle charge voltage: -4mV/°C/Cell.
- ※ There are a number of factors that will affect the length of cyclic service.
- The most significant are depth of discharge, ambient temperature, discharge rate, and the manner in which the battery is recharged.
- Generally speaking, the most important factors is depth of discharge.

Bolt	M5	M6	M8
Terminal	F3 F4 F13 F18 T25 T26	F8 F11 F12-1 F15	F5 F9 F10 F12 F14 F16
Torque	6-7N-m	8-10N-m	10-12N-m